

→ ALL MUSIC DISPLAYS REQUIRE  
A MINIMUM ORDER OF 5 EACH. ←

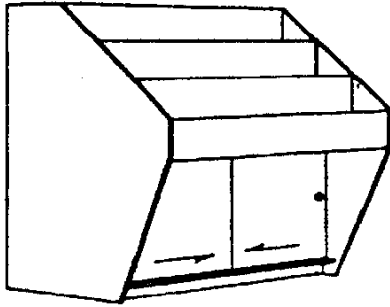

CD & LP

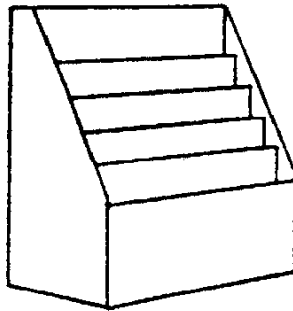

CD & LP

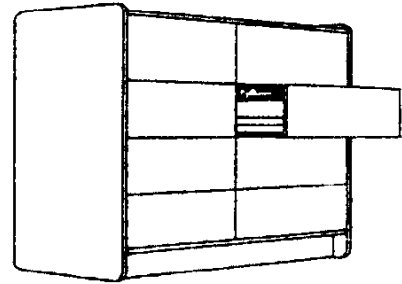

CD Storage

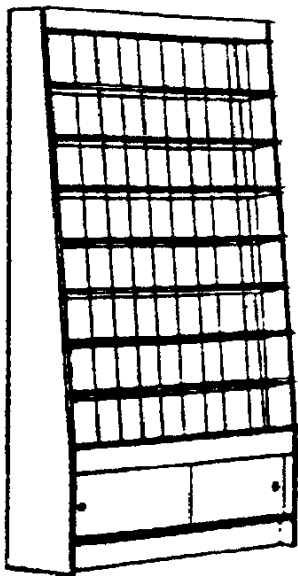

Cassettes

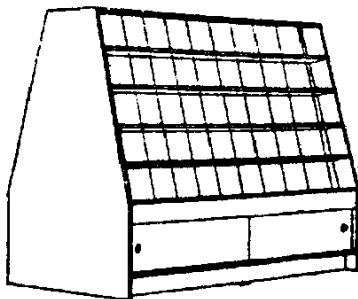

Cassettes

## Music Displays

*"Unique Display Ideas for Your Music"*

We design and manufacture music point of purchase displays in vinyl, melamine and high pressure laminates. Other features include:

- custom trim colors
- custom designs in quantity
- three standard colors - Almond, White, Gray
- ready-to-assemble construction or fully assembled
- fully cartoned
- complete manufacturing facilities
- **██████████** a complete store, including the layout, is our specialty.

*For a quote on your displays or additional information, contact:*



**WOODCRAFT INDUSTRIES, INC.**

Box 79580, Fort Worth, Texas 76179

1-800-383-8961

WOODCRAFT INDUSTRIES, INC.

[HTTP://WWW.HAWKPCI.NET/WII](http://www.hawkpci.net/wii)



# WOODCRAFT INDUSTRIES, INC.

P.O. BOX 79580 (809 BURLINGTON RD.)  
FORT WORTH, TEXAS 76179  
800-383-8961 or 817-232-8961 | 817-847-6929 FAX

## Audio Displays Terms & Conditions

<http://hawkpci.net/wii>  
[wii@hawkpci.net](mailto:wii@hawkpci.net)

### **Terms:**

Payment in full due with order. No C.O.D.s! No credit cards. All checks accepted. No orders will be processed before payment is received. Sales tax on all orders in Texas.

### **Shipping:**

All displays are shipped by common carrier only (ABF Freight System), ready to assemble, boxed, and strapped to pallets which are \$25 each. All shipments are F.O.B. at Woodcraft Industries, Inc., Fort Worth, Texas. Your order is your property when it is placed on the truck and the driver accepts it by signing the Bill of Lading. All freight charges are payable to the carrier upon delivery of your order. Do not pay the freight charges to us. You are responsible for unloading the truck - not the carrier. Inside delivery and notification before delivery is available at extra charge if requested when placing your order. You are responsible for advising us of your receiving hours. Refused shipments may be subject to redelivery charges as determined by the carrier. We will not be responsible for redelivery charges. You will receive a copy of the Bill of Lading that includes the PRO number and Bill of Lading Number, which is the same number as the Sales Order number. To check on your shipment call the carrier and tell them that number. You can find the delivering terminal's telephone number in the business white pages of your telephone book, or click on the ABF link above. Telephone us immediately if you experience any problems with your delivery. Your order is shipped at the most competitive rate that we can negotiate. You may request an estimate of the freight charges when you place your order. We will not guarantee or quote freight charges. Our only responsibility is to place your order on the carrier's truck.

### **Damaged or Missing Parts:**

Please inspect your order upon receipt. Note any visible damage on the Freight Bill and ask the driver to initial it. Claims for concealed damage must be made within five days of delivery. Claims will not be accepted after that time. Notify us immediately about missing parts so that we may replace them as soon as possible. Missing or damaged parts will be provided at no charge only for claims made within five days of delivery. Missing or damaged parts are shipped via common carrier or UPS ground. Airfreight may be available at the customer's expense. Our liability for missing or damaged parts is limited to replacing the parts. We will not be responsible for lost wages or revenue, installation charges, or any other charges beyond replacing missing or damaged parts.

### **Lead Time:**

Most orders shipped within ten working days after receipt of payment.

### **Delays:**

We will not be responsible for delays caused by damaged or missing parts, material shortages, machinery breakdowns, fire, storm, strikes, freight delays, or for any other reason beyond our control.

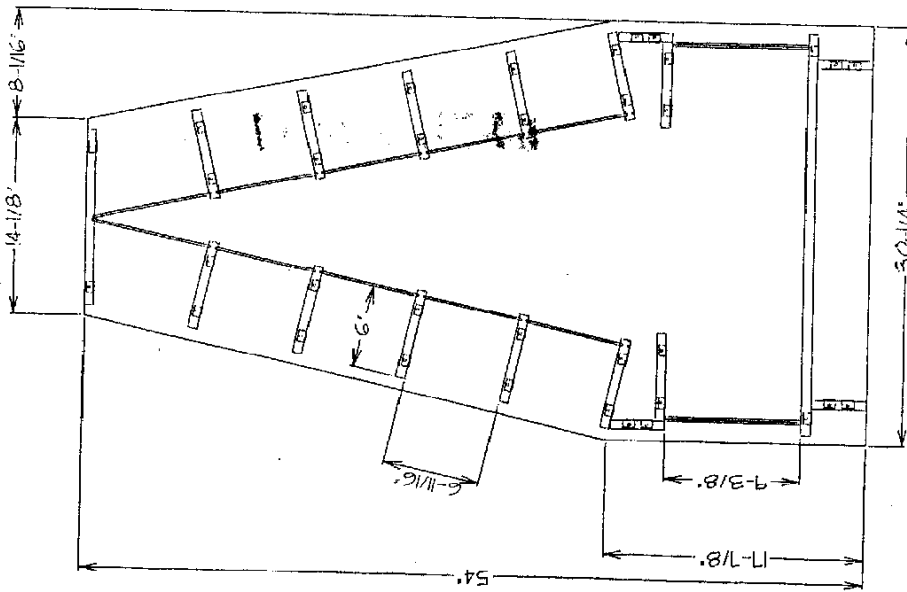
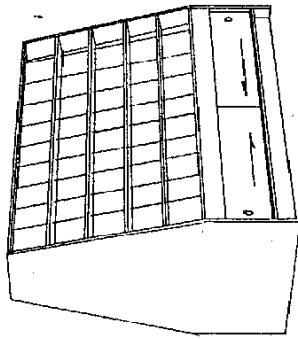
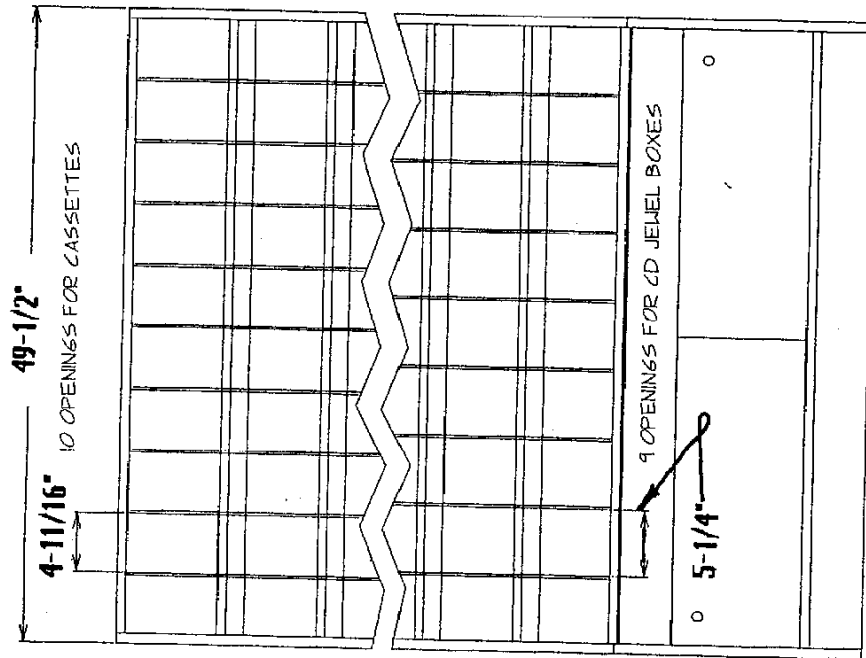

**THIS UNIT WILL DISPLAY 788  
CASSETTES IN SHORT SECURITY BOX  
OR  
1440 CD JEWEL BOXES**

**CA-48-10  
COST = \$298.00  
WEIGHT = 225 LBS.**

**10/01/96 Min - Sec.**



**REVISED 6/9/93**

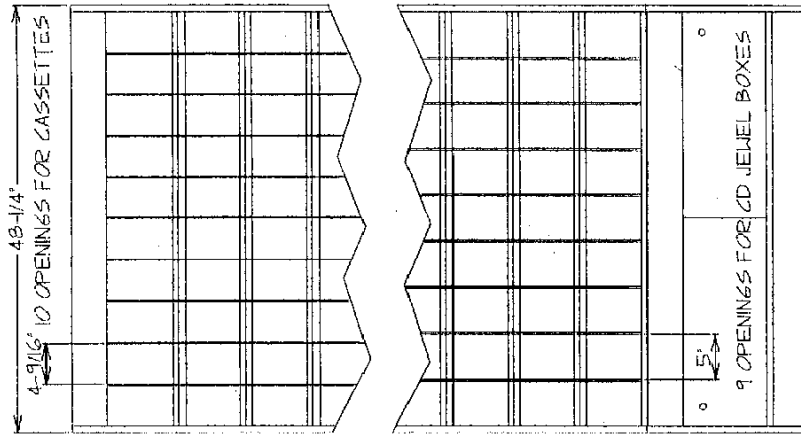
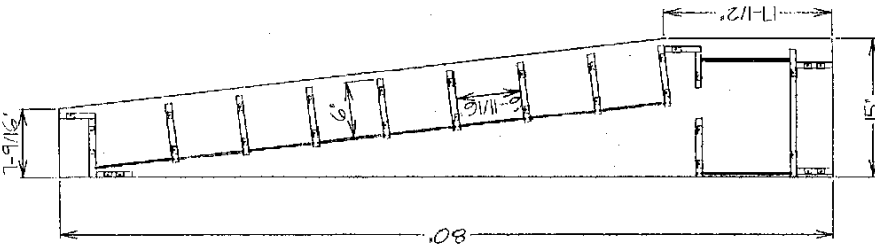
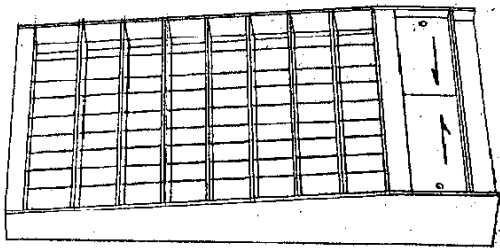

THIS WALL UNIT WILL HOLD UP TO  
 680 CASSETTES IN SHORT SECURITY BOXES  
 OR  
 1,162 CD JEWEL BOXES

**CAW-48-8**

5 THRU 25 - \$260.00  
 25 OR MORE - \$252.00  
 WEIGHT - 160 LBS.

10/01/96

**WOODCRAFT INDUSTRIES, INC.**  
 P.O. Box 79580 • Fort Worth, TX 76179  
 1-800-368-8911 • FAX 817-547-6929

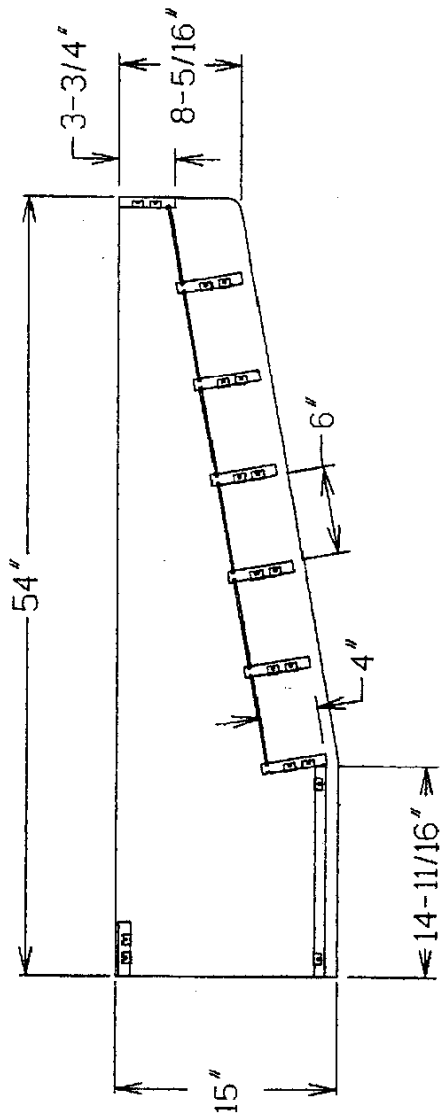

CAW18-6  
SCALE: 1" = 1'

**CAW18-6**

PRICE: 5-9 - \$118.00  
10 OR MORE - \$95.00  
WEIGHT: 60 LBS.

ATTN: THIS DISPLAY IS 18" INSIDE, IT WILL  
DISPLAY JEWEL BOXES FACE OUT, CASSETTES  
FACE OUT AND VIDEOS FACE OUT OR SPINE OUT ON  
THE TOP SHELF.

WOODCRAFT INDUSTRIES INC.  
P.O. BOX 79580, 809 BURLINGTON ROAD  
FAX 1-817-847-6929  
FORT WORTH, TEXAS 76179-0580  
817-232-8961 OR 1-800-383-8961

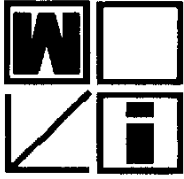

# WOODCRAFT INDUSTRIES, INC.

P.O. BOX 79580 809 BURLINGTON RD.  
FORT WORTH, TEXAS 76179  
(817) 232-8961 (800) 383-8961

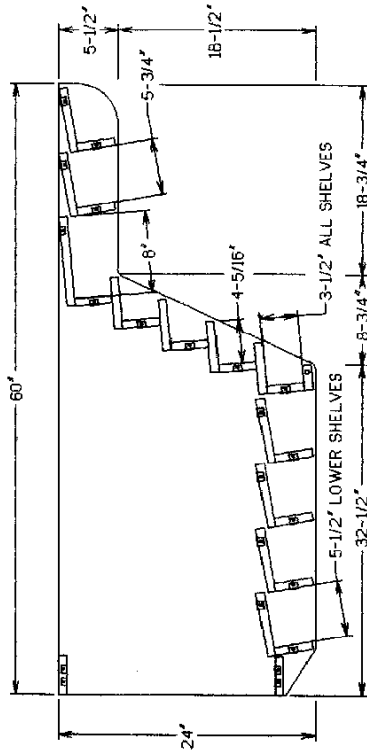

**CD-2**  
**\$250.00**  
**385 ALPHA CASES**  
**616 JEWEL BOXES**

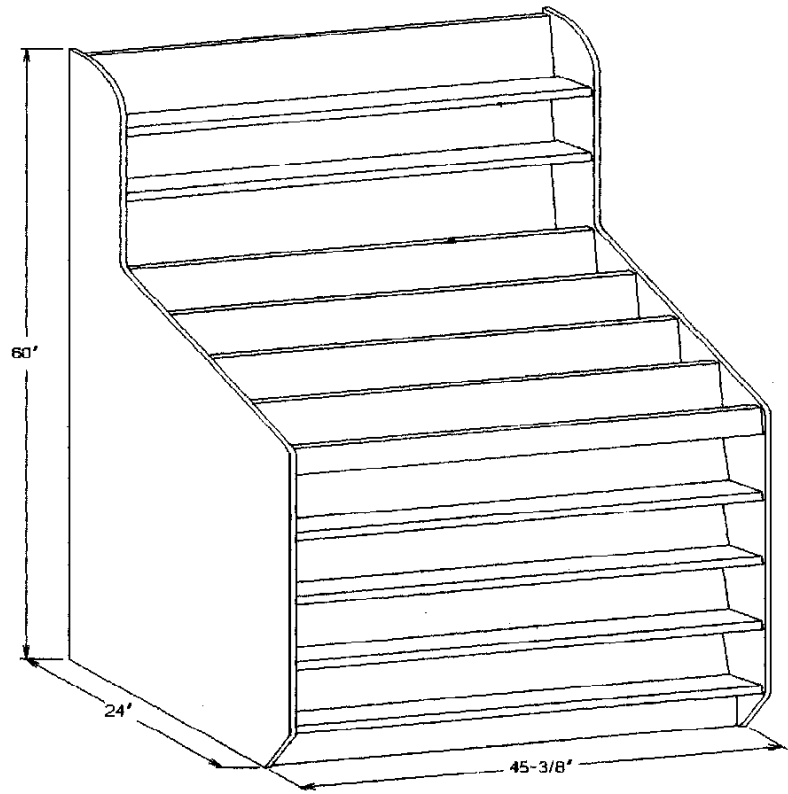

**MINIMUM ORDER**

**OF FIVE EACH**

**FAX (817) 847-6929**

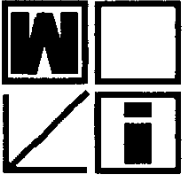

**WOODCRAFT  
INDUSTRIES, INC.**

P.O. BOX 79580 809 BURLINGTON RD.  
FORT WORTH, TEXAS 76179  
(817) 232-8961 (800) 383-8961

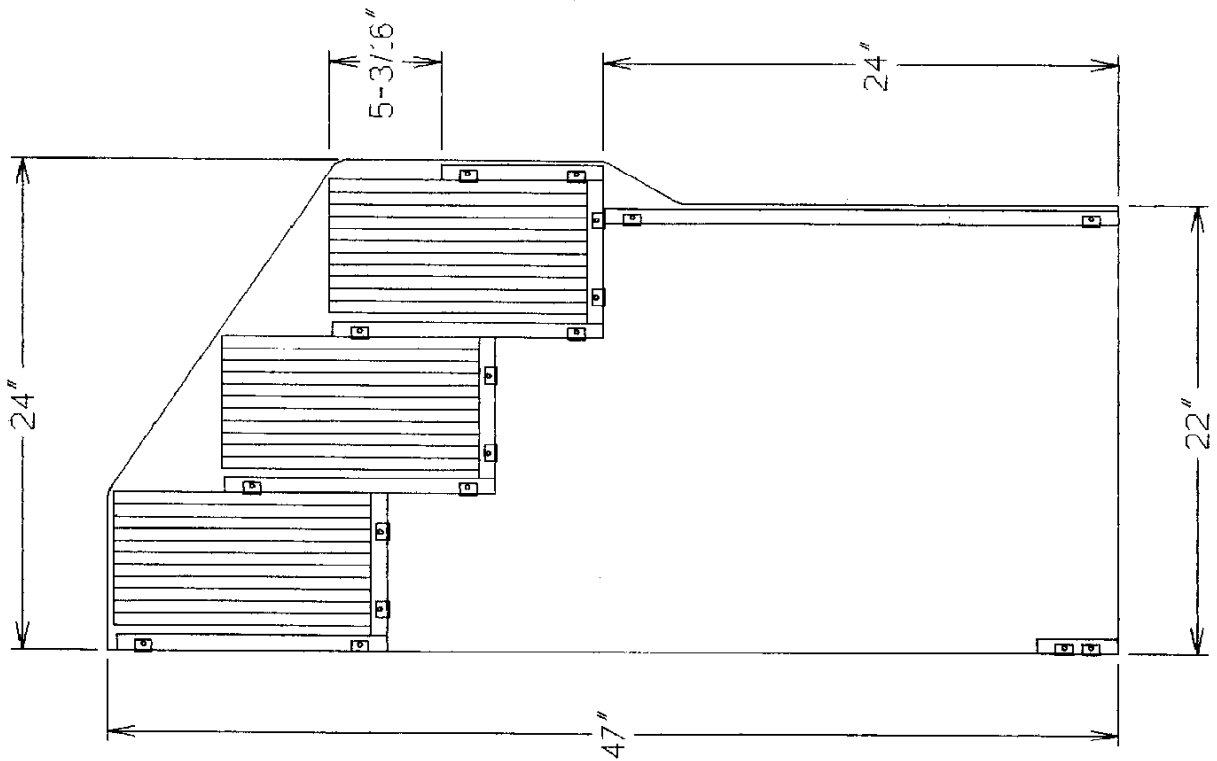

**CD-3 (for long security box)**  
**\$175.00 (\$200.00 with wire dividers)**  
**Capacity: 264 (maximum)**  
**Dimensions: 51"W X 47"T X 24"D**

FAX (817) 847-6929

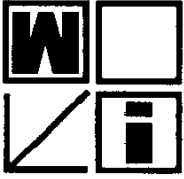

# WOODCRAFT INDUSTRIES, INC.

P.O. BOX 79580 809 BURLINGTON RD.  
FORT WORTH, TEXAS 76179  
(817) 232-8961 (800) 383-8961

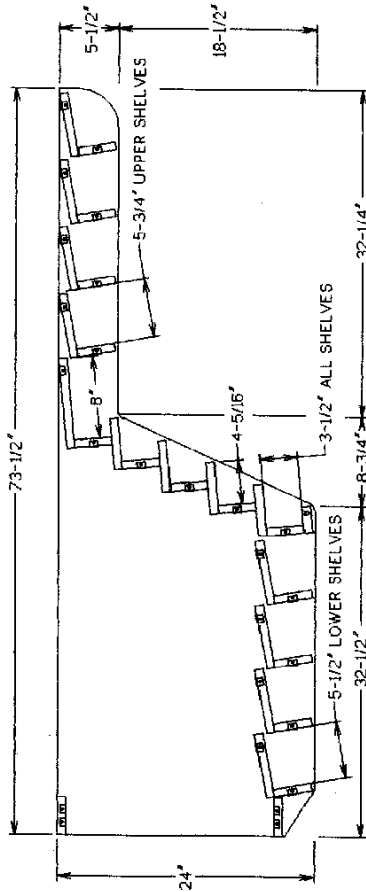

**CD-4**  
**\$275.00**  
**455 ALPHA CASES**  
**728 JEWEL BOXES**

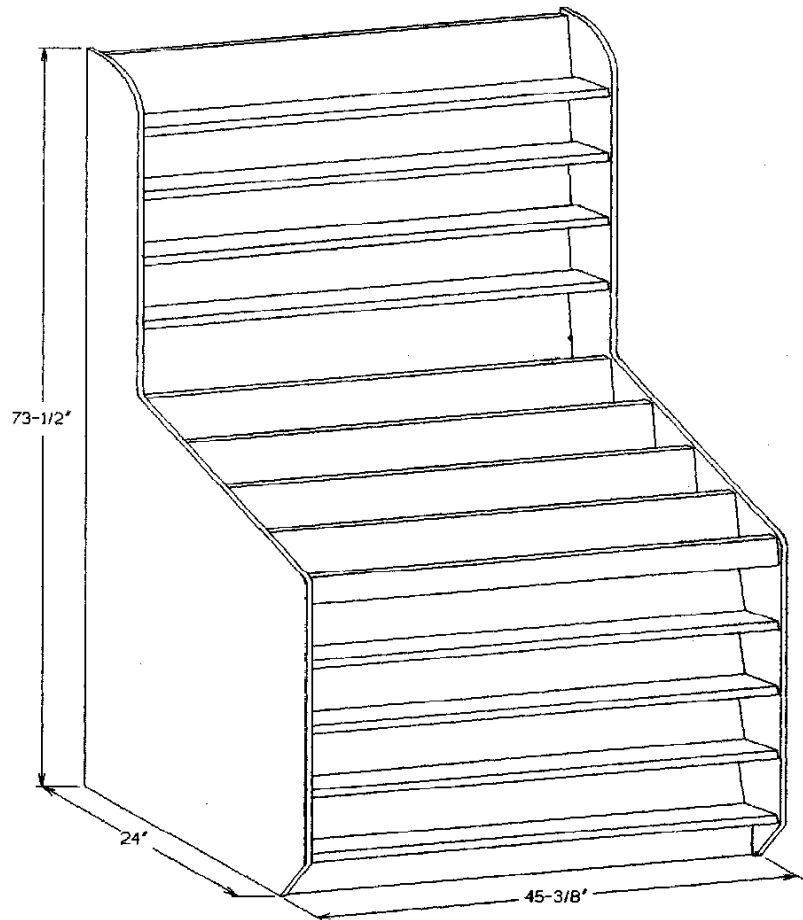

**MINIMUM ORDER**

**OF FIVE EACH**

**FAX (817) 847-6929**

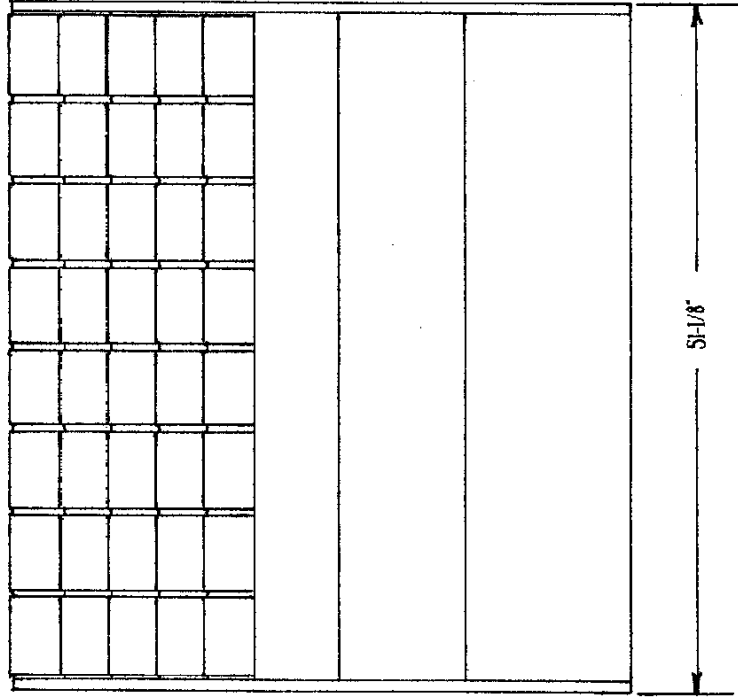
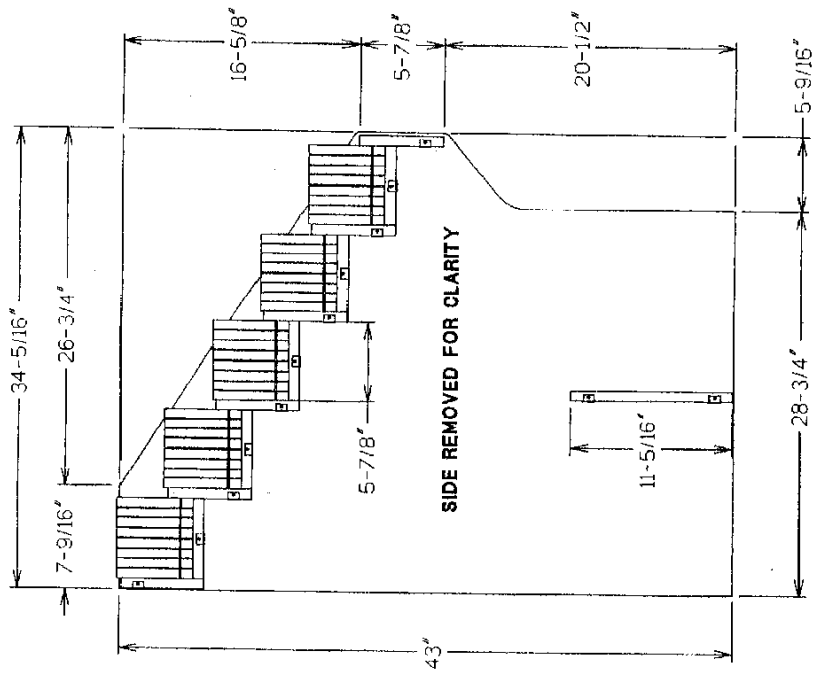

**CD-5**

PRICE: 5-9 - \$225.00  
 10 OR MORE - \$206.00  
 WEIGHT: 130 LBS.

MAXIMUM CAPACITY  
 560 JEWEL BOXES  
 320 JEWEL BOXES IN THE  
 ALPHA SECURITY  
 CASE

WOODCRAFT INDUSTRIES INC  
 P.O. BOX 79380  
 FORT WORTH TEXAS 76179  
 817-232-8961 OR 1-800-383-8961  
 REVISED 12-8-94

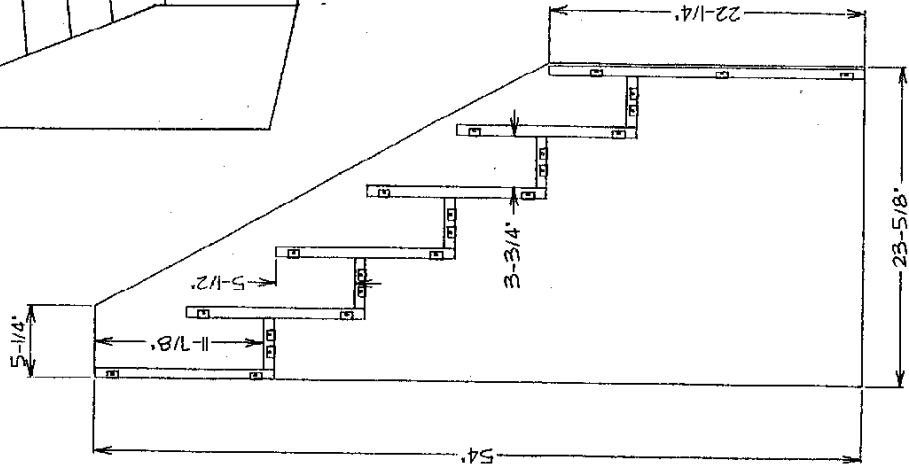
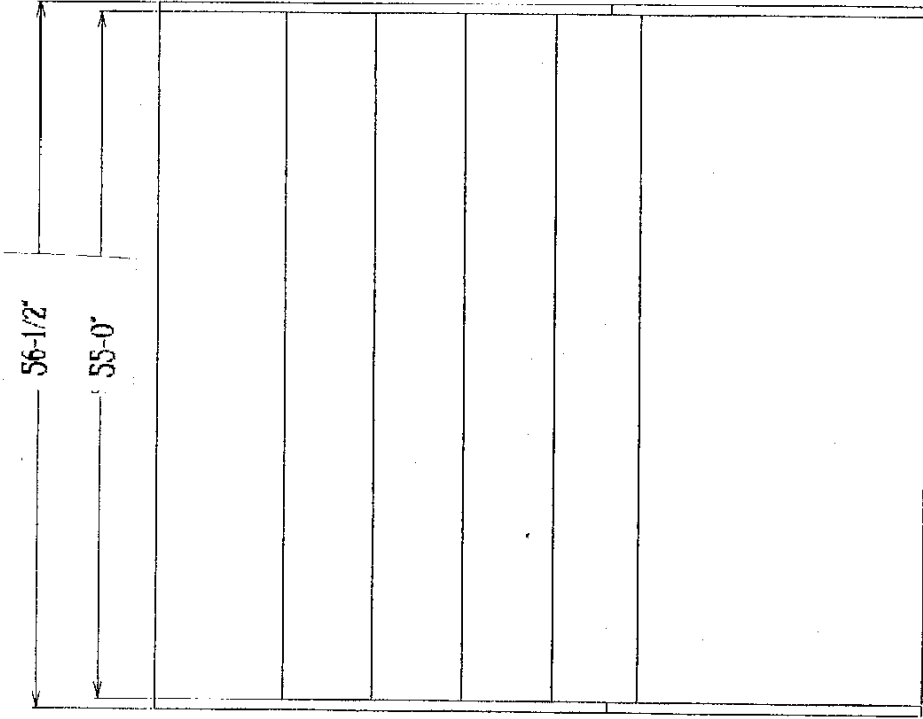
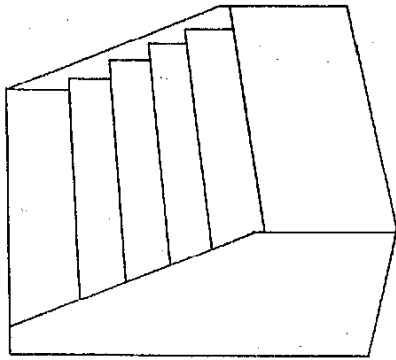

**CD55-5D**  
 5 THRU 25 - \$238.00  
 25 OR MORE - \$226.00  
 WEIGHT - 160 LBS. [INCLUDES DIVIDER PINS]  
 11/14/96

THIS UNIT WILL DISPLAY CD'S, LP'S AND LD'S  
 MAXIMUM CAPACITY FOR CD'S IS 280  
 MAXIMUM CAPACITY FOR LD'S IS 360  
 MAXIMUM CAPACITY FOR LP'S IS 360

**WOODCRAFT INDUSTRIES, INC.**  
 P.O. Box 79880 • Fort Worth, TX 76179  
 1-800-333-8961 • FAX 817-847-6929

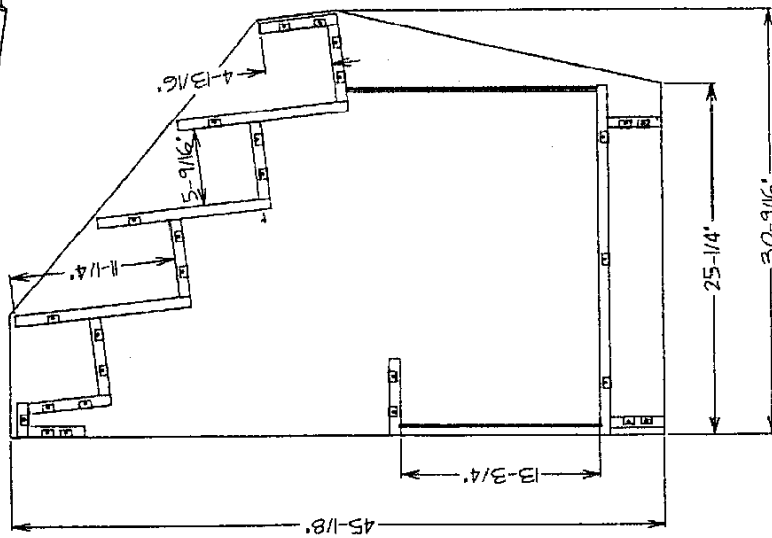
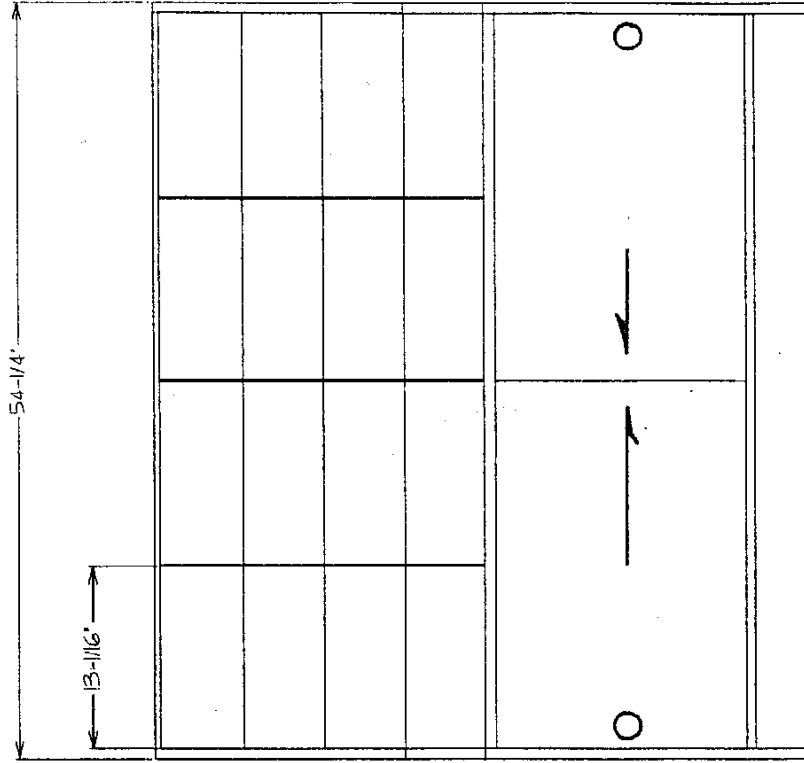
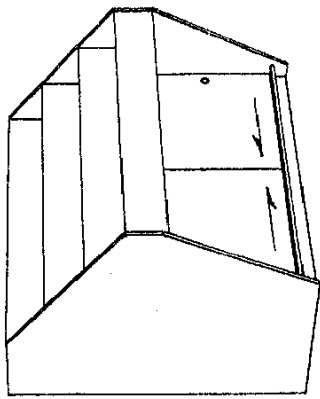

THIS FLOOR UNIT WILL DISPLAY CD'S, LD'S, & LP'S.

MAXIMUM CAPACITY FOR CD'S IS 288

MAXIMUM CAPACITY FOR LP'S IS 368

MAXIMUM CAPACITY FOR LD'S IS 368

CDI-54-4

5 THRU 25 \$295.00

25 OR MORE \$280.00

WEIGHT - 160 LBS.

10/01/96

**WOODCRAFT INDUSTRIES, INC.**  
 P.O. Box 79580 • Fort Worth, TX 76179  
 1-800-383-8961 • FAX 817-847-6929

CS-10 CASSETTE DISPLAY  
 PRICE 5-OVER \$225.00

**WOODCRAFT  
 INDUSTRIES, INC.**

P.O. BOX 79580 809 BURLINGTON RD.  
 FORT WORTH, TEXAS 76179  
 (817) 232-8961 (800) 383-8961

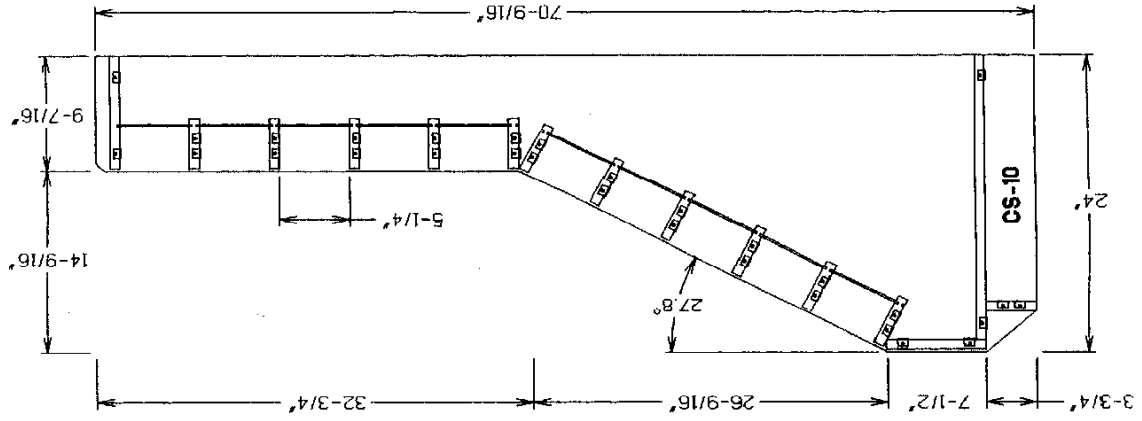

**WOODCRAFT  
 INDUSTRIES, INC.**

P.O. BOX 79580 809 BURLINGTON RD.  
 FORT WORTH, TEXAS 76179  
 (817) 232-8961 (800) 383-8961

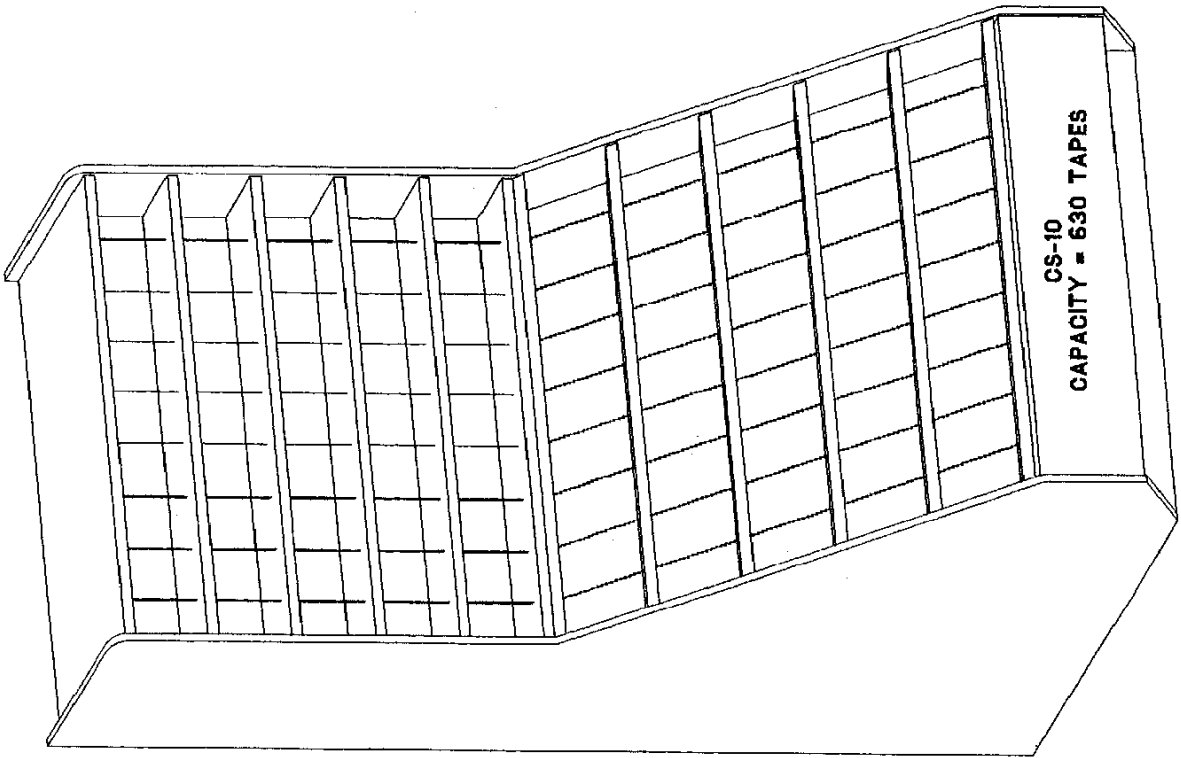

FAX (817) 847-6929

FAX (817) 847-6929

CS-B CASSETTE DISPLAY  
 PRICE 5-OVER \$225.00

**WOODCRAFT  
 INDUSTRIES, INC.**

P.O. BOX 79580 809 BURLINGTON RD.  
 FORT WORTH, TEXAS 76179  
 (817) 232-8961 (800) 383-8961

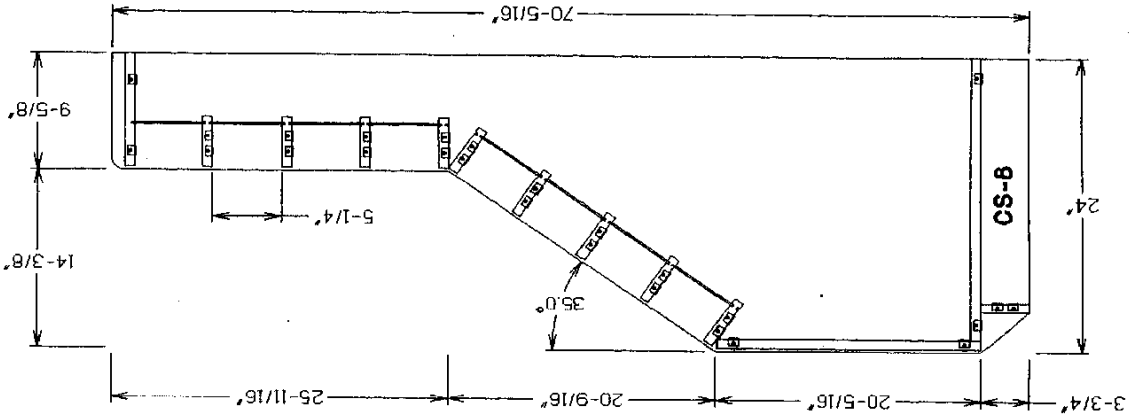

**WOODCRAFT  
 INDUSTRIES, INC.**

P.O. BOX 79580 809 BURLINGTON RD.  
 FORT WORTH, TEXAS 76179  
 (817) 232-8961 (800) 383-8961

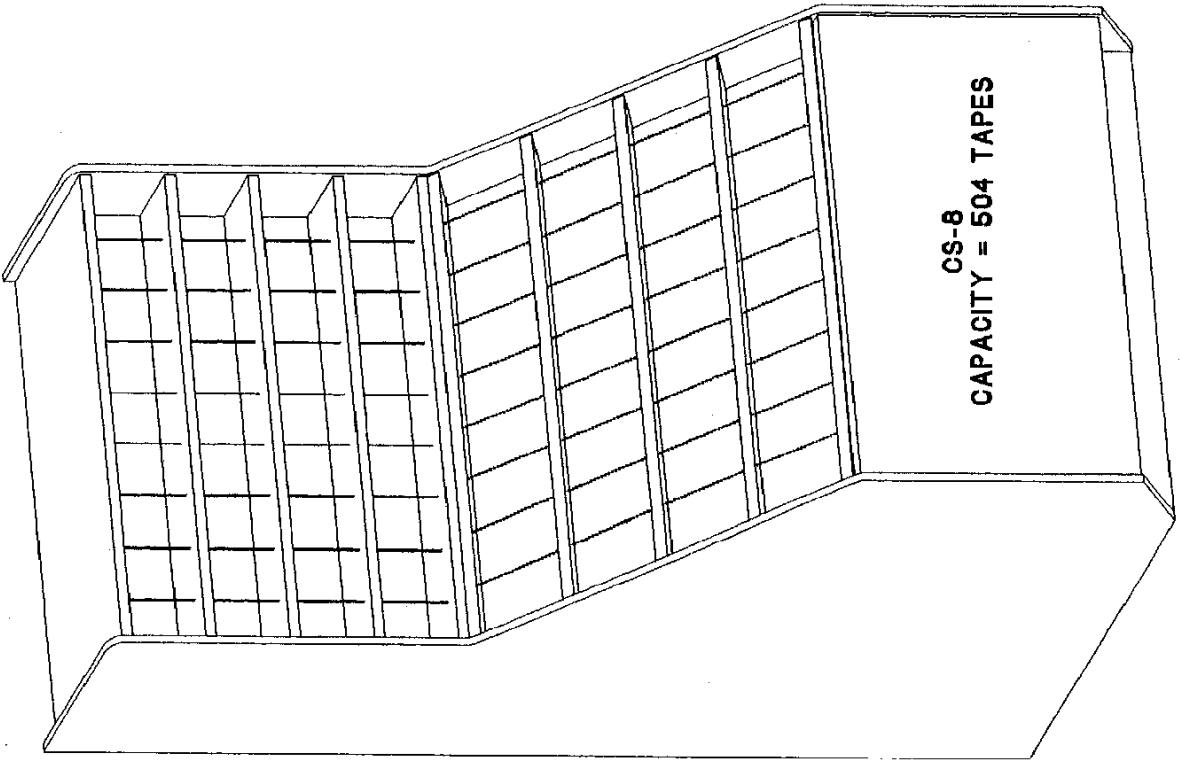

FAX (817) 847-6929

FAX (817) 847-6929

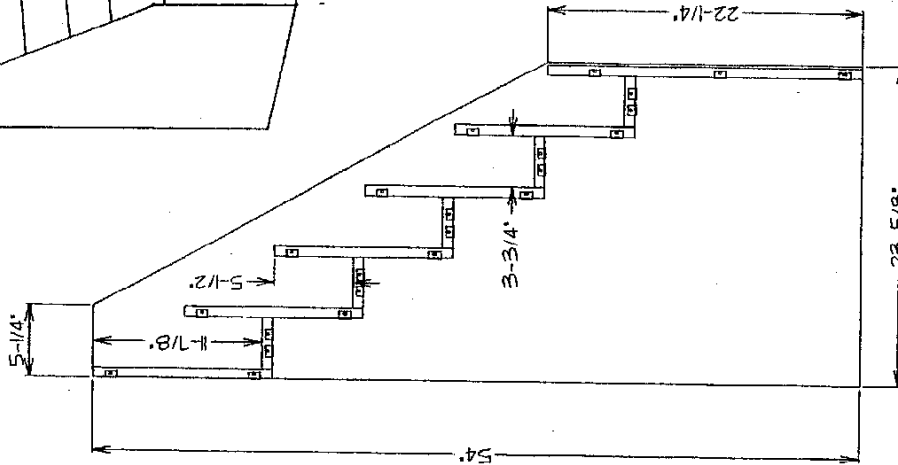
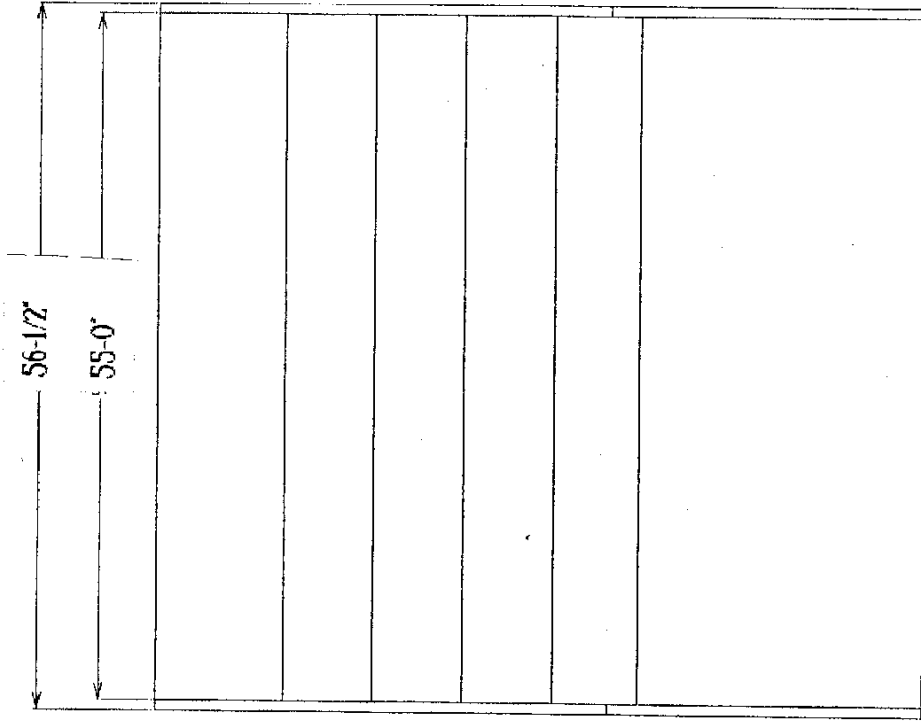
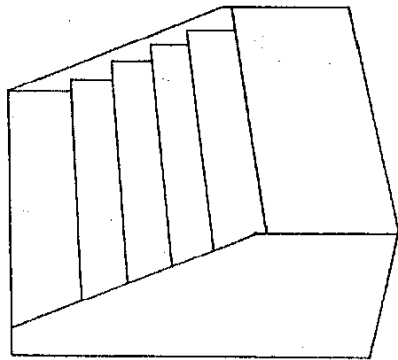

**CD 55-5D**  
 5 THRU 25 - \$238.00  
 25 OR MORE - \$226.00  
**WEIGHT - 160 LBS. [INCLUDES DIVIDER PINS]**  
 11/14/96

THIS UNIT WILL DISPLAY CD'S, LP'S AND LD'S  
 MAXIMUM CAPACITY FOR CD'S IS 280  
 MAXIMUM CAPACITY FOR LD'S IS 360  
 MAXIMUM CAPACITY FOR LP'S IS 360



**WOODCRAFT INDUSTRIES, INC.**  
 P.O. Box 79580 • Fort Worth, TX 76179  
 1-800-333-8961 • FAX 817-847-6929